

Stationary concrete pump

BSA 1005 D3B C

Output up to 52 m³/h
Delivery pressure up to 70 bar

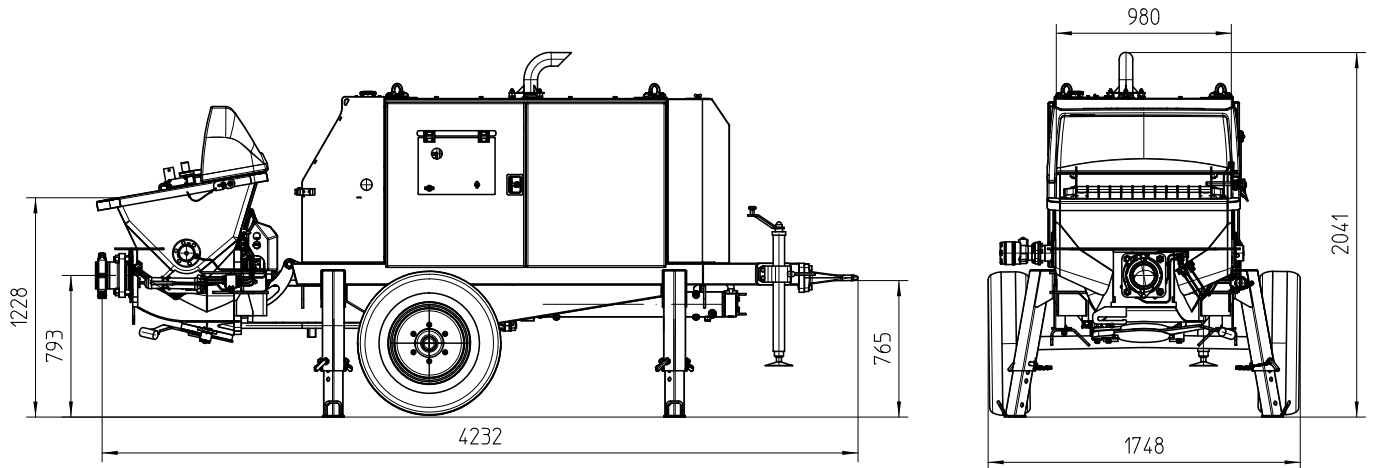

Note: Standard. Dimensions and weights depend on equipment. Subject to technical modifications and errors.

Technical data

Model		BSA 1005 D3B C
Material number		102365.000
Output	m ³ /h	52
Delivery pressure	bar	70
Delivery cylinder	Ø mm	180
Delivery cyl. stroke	mm	1000
Strokes / minute		34
Engine / motor power	kW	55.4
Hopper		RS 487K
Capacity	l	approx. 350
Filling height	m	1.2
Transfer tube		S 1812
Line connection	mm	SK 125
Pressure connection	"	5.5
Control system		SPC-OPS
Diesel tank	l	120
Weight	kg	2700

Serial equipment

Agitator safety switch off	Outriggers 4× mech.
Cable remote control 10 m	Set-up foot mech.
Central lubrication on hopper with hand lever press	Speed drawdown automatically on pump stop
Cleaning accessories	Splash guard
Coloring: Pump, frame, roof, tank and hood anthracite-grey Doors chrome yellow	Tool set incl. standard equipment
Concrete hopper with agitator	Trailer F8, travelling in site
Coupling ring (DIN)	
Drive diesel, Deutz 55.4 kW, Stage 3B	
Electronic error management	
Ergonic Graphic Display (EGD)	
Flushing water pump 50 l/min 20 bar	
Grill 60 mm	
Operating manuals (1× paper, 1× CD-ROM) spare part list	

All data maximum theoretical

See quotation for exact serial delivery scope.
Comprehensive range of options available on request.