



**Putzmeister**

# Stationary concrete pump

## BSA 1006 D5 BSA 1006 E

Output up to 64 m<sup>3</sup>/h  
Delivery pressure up to 55 bar

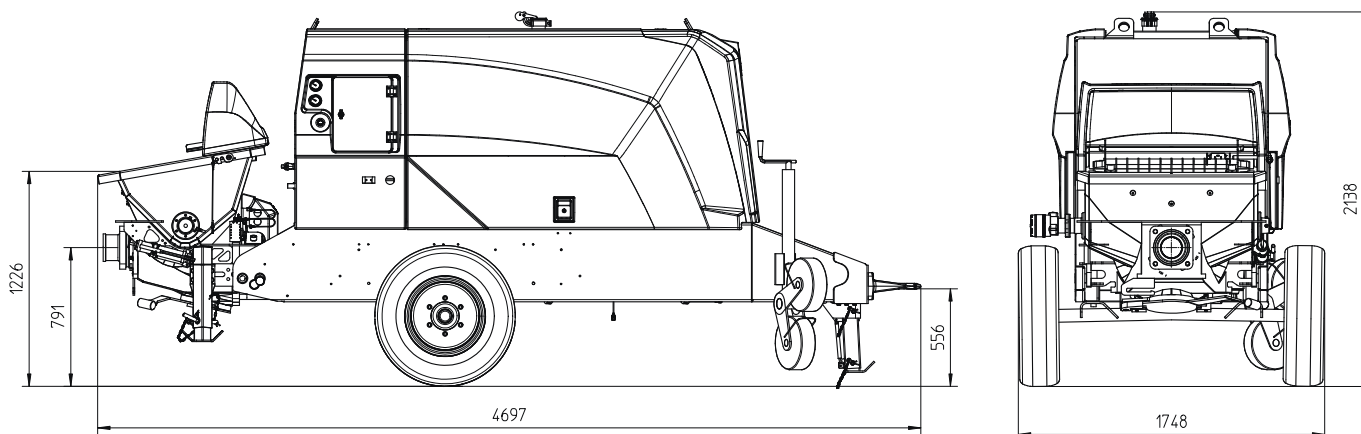

Dimensions and weights depend on equipment. Subject to technical modifications and errors.

### Technical data

| Model                |                   | BSA 1006 D5 | BSA 1006 E |
|----------------------|-------------------|-------------|------------|
| Material number      |                   | 102684.000  | 102685.000 |
| Output               | m <sup>3</sup> /h | 64          | 59         |
| Delivery pressure    | bar               | 55          |            |
| Delivery cylinder    | Ø mm              | 180         |            |
| Delivery cyl. stroke | mm                | 1000        |            |
| Strokes / minute     |                   | 42          | 38         |
| Engine / motor power | kW                | 55.4        | 45         |
| Hopper               |                   | RS 488      |            |
| Capacity             | l                 | approx. 300 |            |
| Filling height       | m                 | 1.23        |            |
| Transfer tube        |                   | S 1812      |            |
| Line connection      | mm                | SK 125      |            |
| Pressure connection  | "                 | 5.5         |            |
| Control system       |                   | Ergonic 3.0 |            |
| Diesel tank          | l                 | 120         | –          |
| Weight               | kg                | 2900        | 3100       |

### Serial equipment

|   |  |
|---|--|
| Agitator safety switch off  | Flushing water pump 50 l/min 20 bar                            |
| Cable remote control 10 m   | Grill 60 mm  |
| Central lubrication on hopper with grease gun                         | Operating manuals (1× paper, 1× CD-ROM) spare part list        |
| Chassis F8  | Output adjustment, electrical                                  |
| Cleaning accessories  | Outriggers 3× mech.  |
| Coloring:<br>Pump, frame, roof anthracite-grey<br>Doors chrome yellow | Speed drawdown automatically on pump stop (Diesel driven only) |
| Concrete hopper with agitator   | Splash guard   |
| Drawbar eye (DIN)   | Support wheel  |
| Drive diesel, Deutz 55.4 kW, Stage 5 (1006 D5)                        | Tool set incl. standard equipment                              |
| Drive electric, 45 kW, iE03 (1006 E)                                  |  |
| Electronic error management   |  |
| Ergonic Graphic Display   |  |

All data maximum theoretical

See quotation for exact serial delivery scope.  
Comprehensive range of options available on request.