

Stationary concrete pump

BSA 2109 H D5

Output up to 95 m³/h
Delivery pressure up to 152 bar

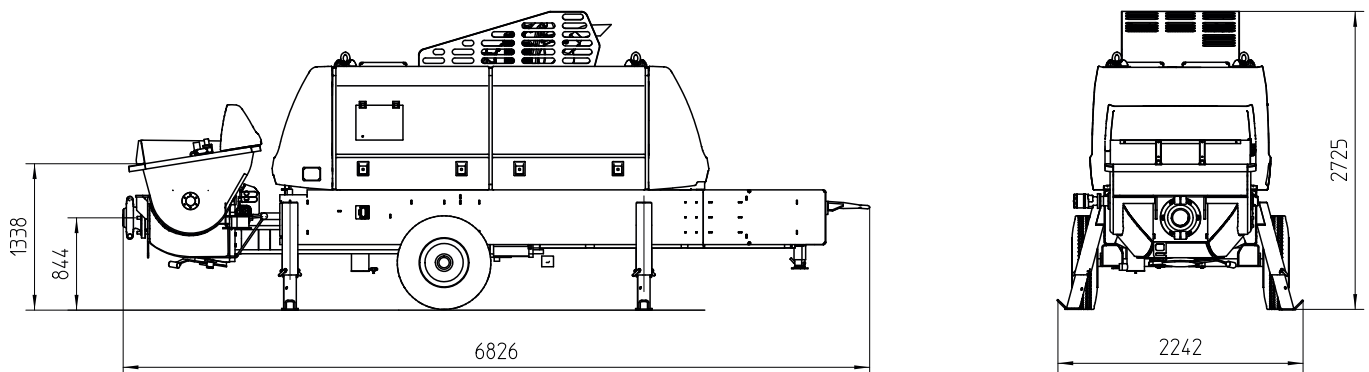

Note: Standard version BSA 2109 H D5. Dimensions and weights depend on equipment. Subject to technical modifications and errors.

Technical data

Model		BSA 2109 H D5
Material number		102419.000
Output	m ³ /h	95 / 57 *
Delivery pressure	bar	91 / 152 *
Delivery cylinder	Ø mm	200
Delivery cyl. stroke	mm	2100
Strokes / minute		24 / 15 *
Engine / motor power	kW	225
Hopper		RS 905 H
Capacity	l	approx. 600
Filling height	m	approx. 1.3
Transfer tube		S 2015 D
Line connection	mm	ZX 150
Pressure connection	"	8
Control system		EPS FFH
Weight	kg	6800

* Values for hydraulic fluid being fed to piston-side
All data maximum theoretical

Serial equipment

Agitator safety switch off	Ergonic Graphic Display (EGD)
Cable remote control 10 m	Flushing water pump
Central lubrication on hopper with hand lever press	50 l/min 20 bar
Cleaning accessories	Gate valve connection
Coloring: Pump, frame, roof, tank and hood anthracite-grey Cover chrome yellow	Grill 60 mm
Concrete hopper with agitator	Hard metal wear parts
Concrete output adjust	Operating manuals (1× paper, 1× CD-ROM) spare part list
Concrete pressure adjust	Outriggers 4× mech.
Coupling ring (DIN)	Pump flow meter
Drive diesel, Deutz 225 kW, Stage 5	Speed drawdown automatically on pump stop
Electronic error management	Splash guard
	Tool set incl. standard equipment
	Trailer F8, travelling in site

See quotation for exact serial delivery scope.
Comprehensive range of options available on request.