

Technical Data

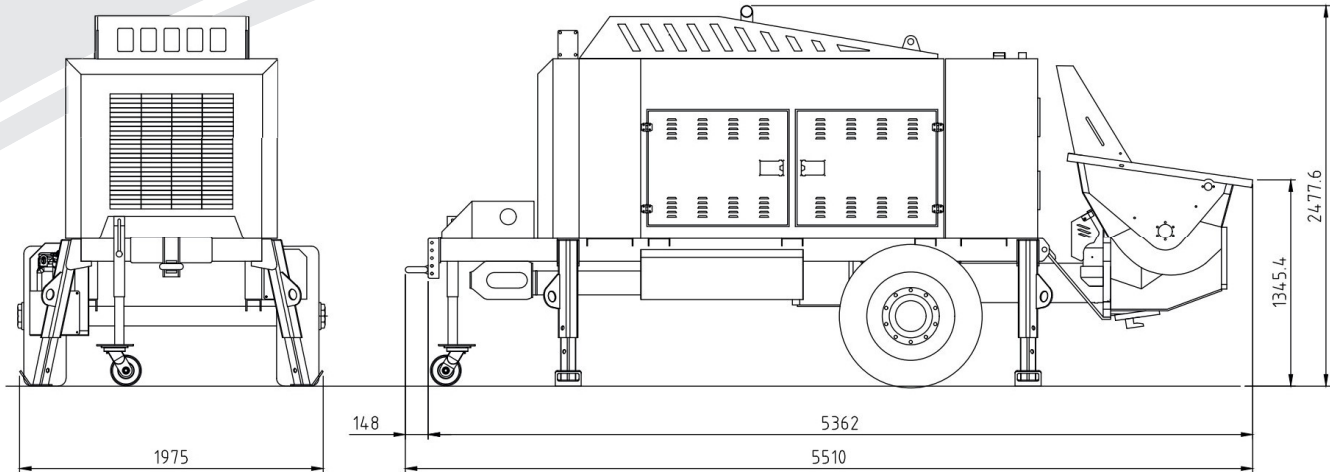

<ul style="list-style-type: none"> Pump specifications 	Wt - 5380kg
Maximum output	Up to 95 [m ³ /h]
Concrete pressure	Up to 70 [bar]
Stroke per minute	Up to 32
Hydraulic Cylinder	Ø130/ Ø80×1400 [mm]
Concrete cylinder volume dimensions	Ø230×1200 [mm]
Hopper capacity	0.6 [m ³]
S-tube	Ø200×Ø180 [mm]
Hydraulic pump	Kawasaki 200S
Max. aggregate size	40 [mm]
Engine	CAT – C7.1 [225kW/301PS]
Engine rpm	2000 rpm
Vertical distance	100 [m]
Horizontal distance	175 [m]

Performance diagram

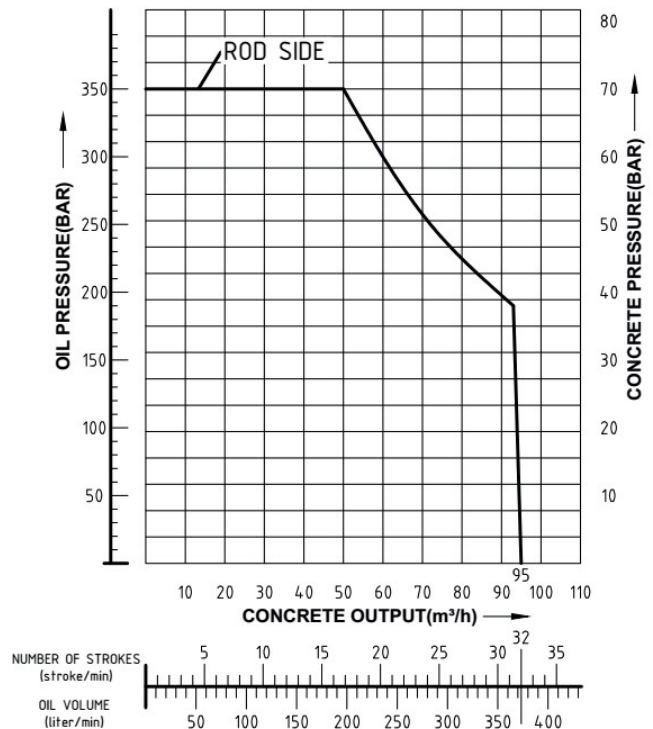

- ⊙ Maximum theoretical values listed
- ⊙ Photos and drawings are for illustrative purpose only
- ⊙ Right to make technical amendments reserved

CPS (International) Ltd
 Unit 6 Howe Lane, White Waltham,
 Maidenhead, Berkshire, SL6 3JP, UK
 T: +44 (0)118 934 3999 | E: info@cps-pipeline.co.uk

